

Sept. 25, 1934.

T. T. BROWN
ELECTROSTATIC MOTOR

1,974,483

Filed Feb. 7, 1930

2 Sheets-Sheet 1

Fig. 1

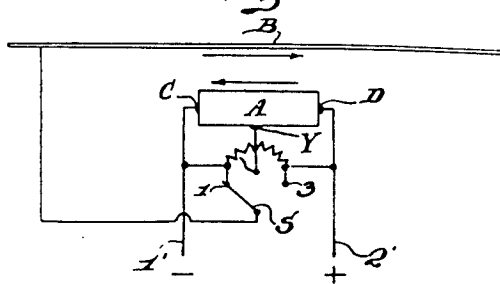

Fig. 2

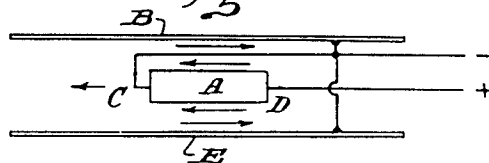

Fig. 3

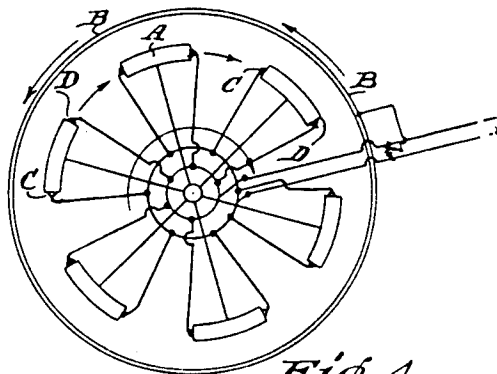

Fig. 6

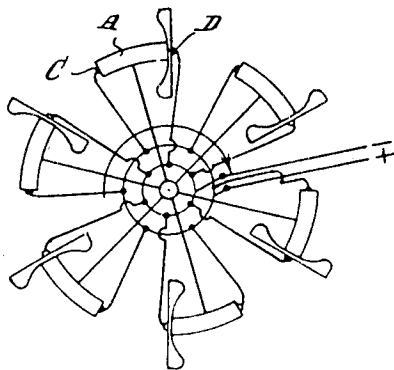

Fig. 4

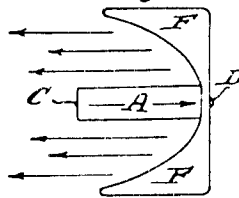
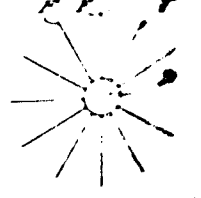

Fig. 5



Thomas T. Brown

384

Milans + Milans

Sept. 25, 1934.

T. T. BROWN

1,974,483

ELECTROSTATIC MOTOR

Filed Feb. 7, 1930

2 Sheets-Sheet 2

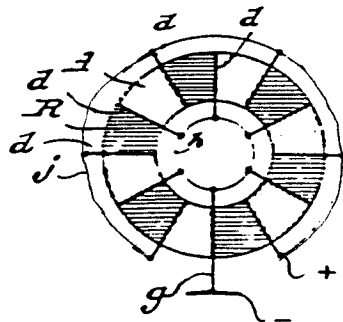
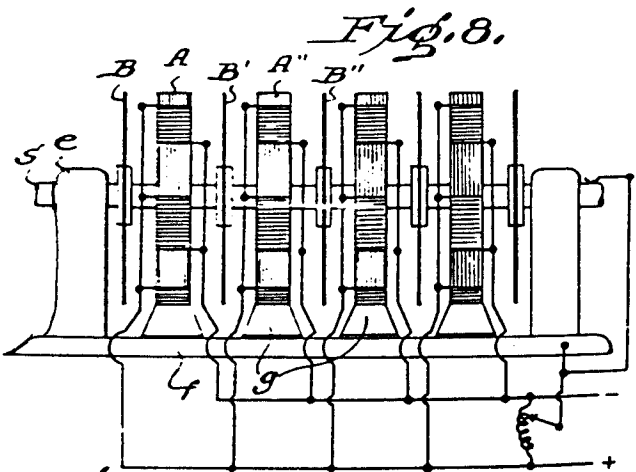
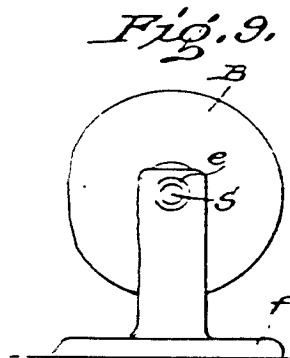
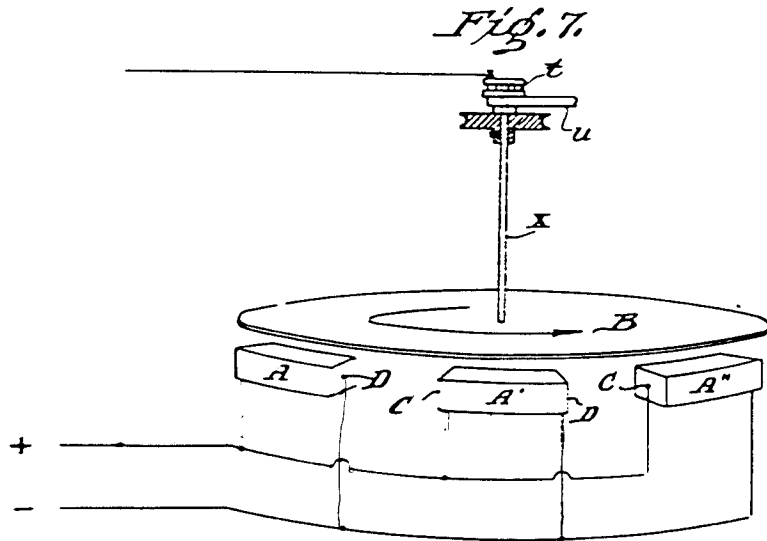

Inventor
Thomas T. Brown

By *Milano & Milano*
Attorney

UNITED STATES PATENT OFFICE

1,974,483

ELECTROSTATIC MOTOR

Thomas Townsend Brown, Zanesville, Ohio

Application February 7, 1930, Serial No. 426,738

12 Claims. (Cl. 172—36)

This invention relates to a method of producing force or motion by applying and maintaining high potential electro-static charges in a system of chargeable masses and associated electrodes.

5 The method involves a certain essential circuit or condition as described herein.

The motor herein described has been found to be useful, especially in the operation of scientific instruments such as those used in observatories for recording the movements of the earth, sun, moon, and etc.

This application is a continuation in part of my previously filed application, Serial No. 139,747.

15 Referring to the accompanying drawings, forming part of this specification,—

Fig. 1 is a diagrammatic view illustrating broadly the essential electrical circuit which is employed in the present case and the direction of forces resulting therefrom.

Fig. 2 is a developed diagram showing the forces involved when the unit A (as in Fig. 1) is partially (or completely) encased.

Fig. 3 is an illustration of similar units arranged about the periphery of a wheel which is encased showing the forces or movement produced when potential is applied.

Fig. 4 is a diagram, with full descriptive data, of a unit with ionizing or radiating fins attached for charging air, oil or other fluid, thus eliminating the need of a charged metallic encasement.

Fig. 5 is an end view thereof.

Fig. 6 is a view of units with ionizing fins as in Fig. 5 arranged on a wheel-like support adapted for rotary movement.

Fig. 7 is an illustration of a simple motor in which the units are stationary and the disc B adapted to rotate by reason of reactive forces.

Fig. 8 is a development of the simple motor shown in Fig. 7. The units are mounted in circular form and are interspaced with discs. The units are stationary and all discs revolve on a common connecting shaft.

Fig. 9 is an end view thereof.

Fig. 10 is a detail view of one circular frame or mounting showing the arrangement of the units. Referring more specifically to the drawings:

In Fig. 1 the machine or apparatus together with the essential electrical circuit is shown in diagrammatic form. The member A is a mass of dielectric or insulation material with terminal plates or electrodes C and D attached thereto at the extremities. A neighboring member B, being a conducting plate or screen, lying in plane parallel and to one side of the alignment of terminals C and D, is connected electrically with one of said terminals attached to member A. For the sake of illustration a three point potentiometer S is shown connecting the member B with either terminal C, the mid-point Y, or terminal

D. When a high potential electro-static charge (100 kv. or over) is introduced to the system between lines 1' and 2' and thence to electrodes C and D respectively, a resultant intense electro-static field is created within and surrounding mass A. When S is in position 1 thus connecting B with C, certain forces are created by and between members A and B which tend to move member A in the direction D to C and member B in the opposite direction. When S is thrown to position 3 thus connecting B with D, the above forces and resultant movements are reversed, causing member A to move in the direction of C to D and member B to react oppositely. If S is thrown to position 2 which represents the average potential or the potential of the mid-point, no forces result between the plate B and mass A. The potentiometer S acts as a means for controlling the potential on plate B and the resultant movement of said plate. Thus the control of potential on plate B influences not only the direction of movement but also the magnitude of the forces involved. An electromotive force of at least 100 kv. seems to be required to produce the results described herein though it is conceivable that a lower voltage may suffice. The forces described herein are only those which operate generally in the alignment, or in the planes parallel to such alignment, of electrodes C and D or, in other words, at right angles to the shortest line connecting members A and B within the plane of C and D.

In Fig. 2 the methods employed and illustrated in Fig. 1 are developed (but not altered) with the addition of another plate or screen E on the opposite side of member A. Since B and E are electrically connected the development may be considered simply a partial or complete encasement of A within member B (or BE).

For practical utilization of the forces developed between A and B, the above encasement can also be made in the form of a cylinder or the like whereby the movement of A with respect to B may be rotational and continuous. Fig. 3 shows such an arrangement using a number of dielectric masses or A members fastened on a wheel-like support and adapted for rotary movement within the cylinder B. The use of transformer oil or other dielectric fluid within said cylinder or other encasement is sometimes desirable.

It is to be understood that in the practical or continuous utilization of the simple devices explained herein the potential difference must be maintained between the terminals attached to the A members. Said A members must be under continual electric strain to produce the desired force or movement. If the A members are movably mounted then the connection with the external electric source must be maintained by means of suitable sliding brushes.

Fig. 4 illustrates another embodiment of the methods employed and explained in Fig. 1. In Fig. 1 the desired forces are created between member A and the conducting plate or screen B.

Fig. 4 illustrates member A as before but substitutes a field of highly charged air, oil or other similar fluid in the place of an actual charged plate or screen. In the latter case the air, oil or other similar fluid is charged by means of radial charging or ionizing fins or vanes F fastened to one electrode of member A. The highly charged fluid is subject to the same reactive forces as member B (in Fig. 1) and moves in the same direction. When in a highly charged condition the member A (in Fig. 4) together with the ionizing fins possesses a force in the direction of C to D and generally in the direction of the alignment of those electrodes. This force or movement is accompanied by a similar and opposite movement in the surrounding field or charged fluid. It is to be understood that the action of the above ionizing fins when used in connection with massive dielectrics preponderously increases the production of forces over that available by the well known pin-wheel effect or reaction from a high voltage point discharge. While the so-called pin wheel forces are perhaps existent, they are negligible and are not to be considered in this specification.

Fig. 5 is an end view showing the radial arrangement of fins F, F', F'', etc. attached at electrode D.

Fig. 6 illustrates a type of motor utilizing a number of units (with ionizing fins) arranged on the periphery of a wheel-like support and adapted for rotary movement. This type is similar to that shown in Fig. 3 so far as the shaft, sliding contacts, bearings and utility are concerned, but differs only in the respect that the surrounding highly charged fluid (in Fig. 6) is substituted for the cylinder B (in Fig. 3). Inasmuch as the fins are the means whereby the fluid is charged, the direction of motion can be definitely determined by connecting the fin with either end of the massive dielectric and the rotation will always be in the direction of the end at which the fin is attached.

In the foregoing description of the operation of the device, the movement of the member A was especially considered as to its practical application and utility in producing force or motion. It must be remembered, however, that the reaction to this movement as well as the movement itself may be utilized. In Fig. 1 the movement of member B, may be utilized as well as the movement of member A. In Fig. 3 the retrograde movement of the cylinder B may similarly be utilized, or as in Fig. 4 it is conceivable that the movement of the fluid thus produced may be utilized for certain purposes.

Fig. 7 is a sketch of a simple reaction type motor in which there are a number of A members fixedly mounted in the form of a ring. The member B (as shown in Fig. 1) is now in the form of a metal disc supported as shown near the ring of A members so that the reactive forces produced thereby will cause continuous rotation of the disc B about the axle X. In Fig. 7 the metal disc B is fastened to shaft X. The ball-bearing (t) supporting the shaft is held on a fixed insulated member (u). Electrical connection to disc B is maintained by conduction from one side of the supply through the bearings and the metal shaft. The electrical connections to the A units are also shown. Direction of rotation

of disc B may be reversed by connecting same with the opposite supply line.

The practical embodiment of the simple method set forth in Fig. 7 is shown in Fig. 8. Fig. 8 is an elevation of a system of metal discs B, B', B'', etc. mounted on a common shaft (s) suitably supported on bearings (e). Stationary circular frames of dielectric masses (A members) similar in function to that shown in Fig. 7 are interspaced at A, A', etc. so that the reaction produced thereby may effect rotation in the adjacent discs. Electrical energy in the form of high potential electro-static charges are readily conducted from an external source to the A members by wires or similar conductors. No sliding contacts are required when the frames of A members are statically mounted. The discs are connected electrically with one another and with one of the two main leads conducting charges to the A members. In Fig. 8 the separate discs are mounted on a common metal shaft which is electrically connected through the bearings to one side of the supply line. Direction of rotation of the discs and shaft may be reversed by connecting same with the opposite side of the supply line. Power and speed of rotation are controlled by the amount of voltage that is supplied to the entire system or by the relative potential of the discs.

Fig. 9 is an end elevation of the motor showing the end disc B and the supporting frame (f), bearing (e), shaft (s), etc.

Fig. 10 is a detail view of the construction, assembly and mounting of the A members in the circular frames as shown in Fig. 8 as A, A', etc. It is apparent that the successive A members must be spaced substantial distances apart in order to prevent electrical breakdown between opposite electrodes of adjacent units. Inasmuch as the forces which are responsible for the movements considered herein are for the most part dependent upon the actual mass or mass gradient of certain dielectrics, it is necessary to have the substance of the A members of different nature and usually more massive than that making up the intervening spacers R. Even though the actual distances between successive positive and negative electrodes may be the same, the difference in the physical nature (especially mass) of the material in the successive spaces A and R produces the forces explained herein. In general, it is advisable to use a dielectric of maximum mass in the construction of the A members and that of minimum mass for the spacers or separators. However, depending upon the other electrical or physical characteristics of the materials used or the arrangement of the same this generalization may not be strictly true.

It is evident from consideration of Fig. 1 that any type of dielectric under the conditions revealed therein produces both direct and reactive forces as shown. These forces, however, are different with dielectrics of different physical characteristics and are roughly proportional to the massiveness. When only one unit or A member is used the results are simple (as shown in Fig. 1). When more than one unit is employed in close proximity the forces created by the dielectric in the spaces oppose and tend to neutralize the forces created by the units but by spacing the units a sufficient distance apart, or interposing an insulating material between the units, which material must be of a lower density than that of the units, neutralization is impossible.

Referring specifically to the Fig. 10, the A members of high density dielectric are so shaped that

they represent segments of the circular frame. These A members are separated from one another by similar segments of low density insulation or the like R. All segments are separated by metal plates (d). Each successive plate is connected alternately to the supply line and thereby given an opposite electrostatic charge. One potential is conducted by means of line (j) to every other electrode. The intervening electrodes are electrically joined by line (h) and grounded through (g) to the metal frame acting as one pole of the machine. The circular frames A, A', etc. are statically mounted in close proximity with the movable system of discs as shown in Fig. 8. When the potential is applied the discs respond to the reactive forces as explained heretofore and thereby cause rotation of the shaft attached thereto.

While the specific construction shown in Figs. 7 and 8 employ stationary frames of A members (a stationary field) and movable reaction plates, it is clear that this invention similarly includes movable frames with stationary reaction plates or movable frames and movable reaction plates. Thus, while the foregoing specifications have outlined in connection with the broader aspects of the invention, certain forms and details, I desire it understood that specific details have been referred to for the purpose of imparting a full and clear understanding of the invention, and not for the purpose of limitation, because it would be apparent that many changes in construction and arrangement, and many embodiments of the invention, other than those illustrated, may be resorted to without departing from the spirit of the invention as intended to be covered by the hereto appended claims.

What I desire to claim by U. S. Letters Patent is:

1. An electro-static motor comprising one or more dielectric masses under electrical strain and a neighboring highly charged plate or body lying generally parallel and to one side of the line of the maximum potential gradient within said masses, whereby opposing forces are created between the charged plate or body and the masses, which forces act in a line running parallel to the aforementioned line of maximum potential gradient, to effect movement in the mechanical elements of the motor.
2. A motor of the character described comprising one or more dielectric masses under electrical strain, a highly charged unipolar element arranged in close parallel relation to the masses and means for controlling the force, speed, power and direction of rotation of the motor by controlling the potential supplied to said unipolar element.
3. Method of producing relative linear motion between a dielectric mass and a conducting plate or screen which consists in applying a difference of potential to the dielectric mass and charging the conducting plate to a potential and by controlling the electro-static potential supplied to said dielectric mass and said plate or screen.
4. Method of producing relative linear motion between a dielectric mass and a conducting plate or screen which consists in supplying different and direct electro-static potentials to the mass and a direct potential to the plate or screen.
5. Method of producing relative linear motion between a movable mass of dielectric with electrodes attached and a fixed conducting plate or screen, which consists in supplying different and direct electro-static potentials to said electrodes

and one of said direct potentials to said fixed plate.

6. A motor of the character described, comprising a dielectric mass under electrical strain, a highly charged unipolar element arranged in close parallel relation to the dielectric mass, and means for controlling the direction of rotation of the motor by controlling the potential supplied to the unipolar element.

7. A motor of the character described, comprising a fixed mass of dielectric having suitable electrodes attached thereto, a movable member having a conducting plate or screen mounted thereon and arranged in close proximity to one side of said electrodes and means for supplying different and constant electro-static potentials to said electrodes and one constant potential to the plate or screen to effect movement of said movable member.

8. A motor of the character described, comprising a movable member having mounted thereon a mass of dielectric with suitable electrodes attached thereto, a fixed plate or screen arranged parallel to one side of said electrodes and means for supplying different and constant electro-static potentials to said electrodes and one constant potential to the plate or screen to effect movement of said mass of dielectric generally in the alignment of its attached electrodes.

9. A motor of the character described, comprising a mass of dielectric with electrodes attached, a fixed conducting plate or screen, means for movably mounting said mass in close relationship with said plate or screen, means for supplying different and direct electro-static potentials to said electrodes, and means for supplying one of said direct potentials to the fixed plate or screen to effect movement of said dielectric mass generally in the alignment of said electrodes.

10. An electro-static motor, comprising a rotary shaft, a metal disc secured thereto, a stationary mass of dielectric provided with two electrodes, said electrodes being positioned to lie parallel to the general line of motion of said disc and in close proximity thereto, and means for supplying different electro-static potentials to said electrodes and supplying one of said potentials to said disc to effect movement of said disc.

11. A motor of the character described, comprising a rotatable shaft having a series of relatively separated discs secured thereto, circular frames constructed of alternate dielectrics of different characteristics fixedly mounted in the spaces between successive discs, each dielectric constituting a segment of the circle, metal electrodes arranged between each segment, means for connecting successive electrodes with alternate sides of a high potential electro-static source and means for connecting said discs to one side of the high potential source to effect rotation of said discs.

12. A motor of the character described, comprising a mechanical part suspended in a non-conducting fluid and having a mass of dielectric secured thereto, said mass having two electrodes, ionizing fins attached to one of said electrodes and extending radially therefrom, and means for supplying different electro-static potentials to said electrodes to effect a relative movement between said mechanical part and the surrounding fluid.

THOMAS TOWNSEND BROWN.